



## Micro Inverter User's Manual

**WVC-1200**  
**WVC-1400**  
**WVC-1600**

**WVC-2000**  
**WVC-2400**  
**WVC-2800**



**Smart Life**



Ver 1.08





## SYSTEM STRUCTURE AND MONITORING MODE

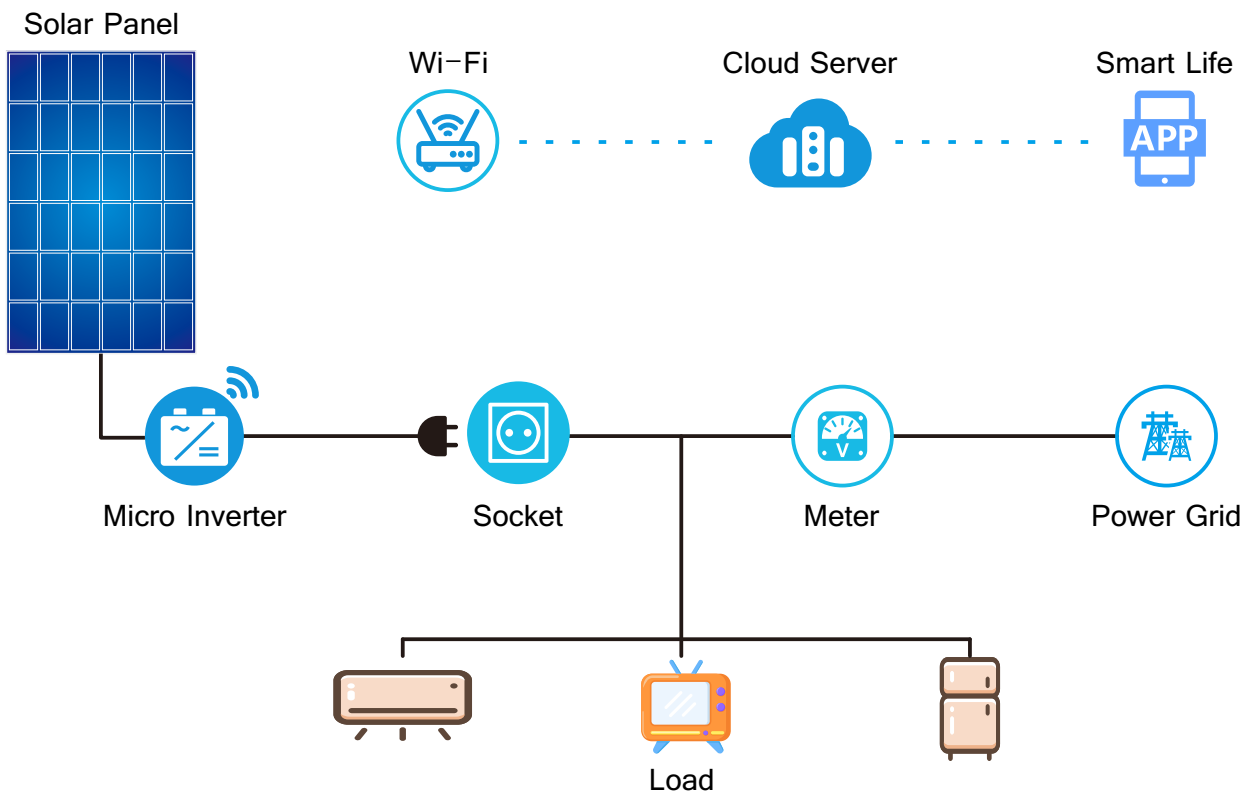

Plug and play, the user will connect the corresponding terminals, and the system will automatically enter the intelligent power supply mode according to the current load operation. When the installation position of the inverter is within the effective Wi-Fi coverage, it can also be connected to the "smart life" "APP, customers can remotely monitor and control equipment

# MICRO INVERTER

Continuous stability & higher efficiency

SUPPORTS REMOTE QUERY AND CONTROL VIA MOBILE PHONE, AND CAN MANAGE MULTIPLE DEVICES UNDER THE SAME ACCOUNT. COMPATIBLE WITH IOS AND ANDROID SYSTEMS, EASY TO SHARE FAMILY MANAGEMENT.



## A BETTER MICROINVERTER

### NEW MODEL OF MICRO INVERTER LAUNCHED

APP remote monitoring real-time data display  
One machine, one secret, cloud data storage

Widest output voltage range of 85-265V  
Automatic voltage recognition everywhere

Hand in hand multiple parallel stacking mode  
Expansion is not restricted by conditions

Excellent low-light lockout (APL)  
Works even in bad weather

Reverse transmission technology  
Up to 93% efficiency or more

Waterproof grade IP67  
Effectively prevent rain erosion



## FEATURES:

- Built-in Wi-Fi communication Smart Life app control
- Wide voltage input (22-60VDC)
- Reverse transmission technology, load priority is used
- Output power is adjustable
- Wide voltage output function
- Automatic voltage conversion function
- Automatic detection of AC 0-angle phase
- Output pure sine wave
- Automatic sunlight sensing function
- Automatic Power Lock (APL)
- Automatically adapt to different load power factors
- Constant current and constant power output
- Grid fault limits output (anti-islanding effect)
- Current limit protection
- Mixed stack of multiple machines
- Built-in power statistics
- Built-in highly integrated NA protection switch
- Over temperature load reduction function
- Automatic power factor compensation
- Solar panel leakage detection/alarm function



The latest generation of Micro Inverters supports balcony solar systems, ground solar systems, and rooftop solar systems. The system can be expanded and installed directly at any time and anywhere without changing the original configuration.

## PARAMETERS

### DC Input

Model	WVC-1200	WVC-1400	WVC-1600	WVC-2000	WVC-2400	WVC-2800
Maximum Input Power	Max 4*375W	Max 4*430W	Max 4*500W	Max 4*625W	Max 4*750W	Max 4*875W
Mppt Voltage Range (Module Open Circuit Voltage)	30~60V					
Starting Voltage	>22V d.c.					
Working Voltage Range	22-60V d.c.					
Maximum Input Current	4×12A	4×14A	4×16A	4×20A	4×23A	4×27A
Maximum Input Short Circuit Current	4×14A	4×16A	4×18A	4×23A	4×28A	4×32A
Maximum Feedback Current Of The Array	0					

### AC Output

Model	WVC-1200	WVC-1400	WVC-1600	WVC-2000	WVC-2400	WVC-2800
Maximum Output Power	1200VA	1400VA	1600VA	2000VA	2400VA	2800VA
Rated Output Current	@120V 10A @230V 5.22A	@120V 11.6A @230V 6A	@120V 13.3A @230V 6.95A	@120V 16.6A @230V 8.7A	@120V 20A @230V 10.5A	@120V 23.5A @230V 12.2A
Nominal Output Voltage Range	@120V a.c. (e.g. Japan, North America, etc.) @230V a.c. (e.g. Europe)					
Nominal Frequency Range	50Hz/60Hz					
Power Factor	> 0.99 default 0.95 leading...0.95 lagging					
Harmonic Distortion Of Output Current	<5%					
Maximum Number Of Connections Per Branch	@120V 3Pcs @230V 6Pcs			@120V 2Pcs @230V 4Pcs		

## Efficiency, Safety and Protection

Model	WVC-1200	WVC-1400	WVC-1600	WVC-2000	WVC-2400	WVC-2800
Peak microinverter efficiency	92.70%					
CEC weighted efficiency	92.50%					
Nominal MPPT efficiency	99.80%					
Night time power consumption (mW)	0					

## Mechanical Data

Model	WVC-1200	WVC-1400	WVC-1600	WVC-2000	WVC-2400	WVC-2800
Ambient temperature range	-20 to +50°C					
Storage temperature range	-20 to +50°C					
Dimensions (L × W × H )	370 × 300 × 41.6mm					
Weight	2.52kg			3.16kg		
Waterproof level	Outdoor NEMA 3R (IP65)					
Cooling method	Natural convection (no fans)					
Degree of pollution	PD3					

## Feature

Model	WVC-1200	WVC-1400	WVC-1600	WVC-2000	WVC-2400	WVC-2800
Power Delivery Mode	Reverse transmission, load priority					
Communication method	Wi-Fi					
Rated transmit power	802.11b: +17dBm ± 1.5dBm (@11Mbps) 802.11g: +15dBm ± 1.5dBm (@54Mbps) 802.11n: +14dBm ± 1.5dBm (@HT20, MCS7)					
Surveillance system	Smart Life					
Warranty	5 years					
Electrical Standard	EN 55011:2016+A2:2021;BS EN 55011:2016+A2:2021 CISPR 11:2015/AMD2:2019; EN IEC 61000-3-2:2019+A1:2021; EN IEC 62311:2020 BS EN IEC 61000-3-2:2019+A1:2021; EN 301 489-1 V2.2.3 (2019-11);IEEE 1547A:2014 EN 301 489-17 V3.2.4 (2020-09); EN 300 328 V2.2.2 (2019-07); DIN VDE V 0126-1-1 (VDE V 0126-1-1):2013-08; VDE-AR-N 4105 (VDE-AR-N 4105):2011-08; DIN VDE V 0124-100 (VDE V 0124-100):2012-07; IEC 62109-1:2010; IEC 62109-2:2011 DIN VDE 0126-1-1 (VDE V 0126-1-1):2013-08 VFR 2019 UL 1741:2010 Ed.2+R:16Sep2020 CSA C22.2#107.1:2016 Ed.4 ABNT NBR 16149:2013; ABNT NBR 16150:2013 ABNT NBR IEC 62116:2012 ANEXO III – parte 2, Portaria n,º 357, de 01 de agosto de 2014					
Bluetooth	2402-2480MHz Bluetooth EIRP Power (Max.) 7.89dBm					
Wifi 2.4G	2412-2472MHz Wifi 2.4G EIRP Power (Max.) 18.08dBm					

\*Note: Voltage and frequency ranges may exceed nominal values if required by the utility company.

## Package

<b>WVC-1200/WVC-1400/WVC-1600</b>	<b>Single (packaging)</b>	<b>FCL (4 units)</b>
G.W.	3.62Kg	15.5Kg
size	430 × 375 × 140mm	440 × 395 × 390mm
<b>WVC-2000/WVC-2400/WVC-2800</b>	<b>Single (packaging)</b>	<b>FCL (4 units)</b>
G.W.	4.26Kg	17.8Kg
size	430 × 375 × 140mm	440 × 395 × 390mm

## About Micro Inverters

WVC-1200/WVC-1400/WVC-1600/WVC-2000/WVC-2400/WVC-2800 Micro Inverters belong to the one-to four series of micro inverters, each of which can connect four photovoltaic modules. This series of micro inverters can efficiently convert direct current (DC) into alternating current (AC) that meets the requirements of the grid and feed the power into the grid.

Each inverter of the WVC-1200/WVC-1400/WVC-1600/WVC-2000/WVC-2400/WVC-2800 series operates independently and monitors the power generation status of the photovoltaic modules in real time to ensure the maximum power generation of the photovoltaic modules and improve the flexibility, availability and reliability of the system.

## About the manual

This manual contains important instructions for WVC-1200/1400/1600/2000/2400/2800 microinverters, which must be read completely before installing or debugging the equipment. For the sake of safety, only qualified technicians who have received professional training or have demonstrated competence can install and maintain this micro inverter under the guidance of this document.

## Other information

Product information is subject to change without notice. This user manual will be updated frequently. Please contact sales for the latest version.

## Illustration

- ① Inverter screw fixing hole
- ② Ground wire connection hole (\*The inverter housing must be connected to the ground wire)
- ③ Connect the solar panel DC input
- ④ Wi-Fi antenna
- ⑤ LED status indicator
- ⑥ Connect to grid/connect to another microinverter

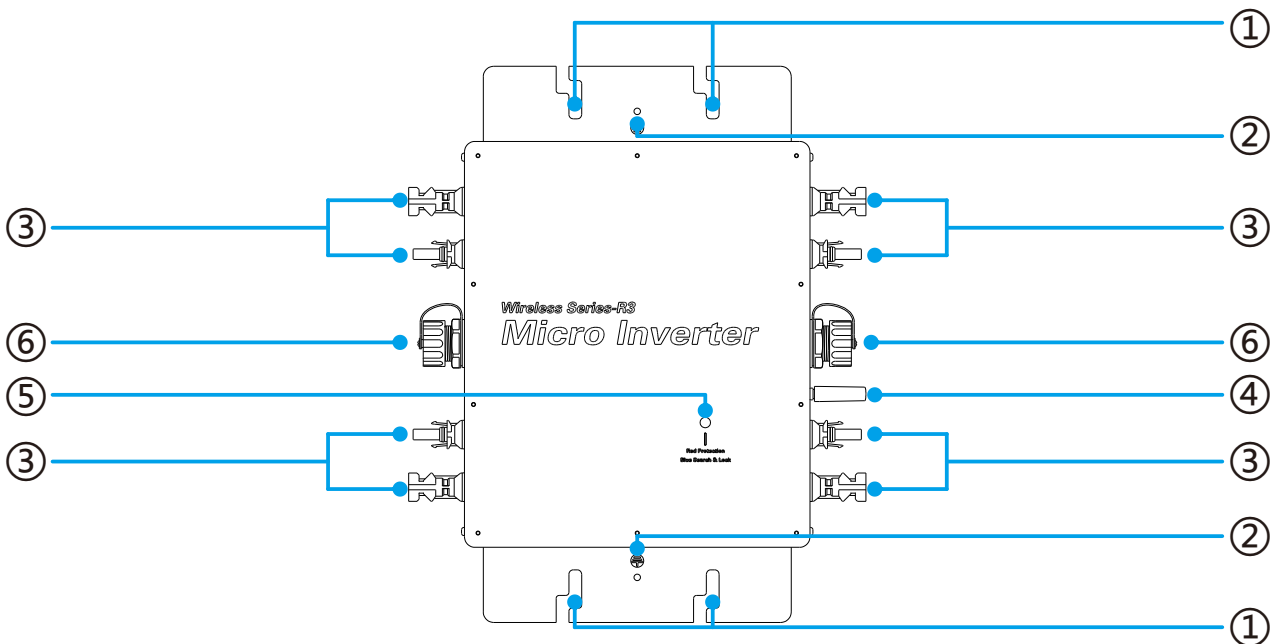

# Manual catalog

<b>1. Important Notes</b>	<b>03</b>
1.1 Product Range	03
1.2 Target Users	03
1.3 Symbols Used	03
<b>2. About safety</b>	<b>04</b>
2.1 Important Safety Instructions	04
2.2 Symbol Description	05
2.3 Radio Interference Statement	05
<b>3. About Products</b>	<b>06</b>
3.1 About the 4-in-1 Product	06
3.2 Emphasis	06
3.3 Terminal Introduction	06
3.4 Dimensions (mm)	06
<b>4. About the function</b>	<b>07</b>
4.1 Work Mode	07
<b>5. About installation</b>	<b>08</b>
5.1 Accessories	08
5.2 Installation Precautions	08
5.3 Required space distance	09
5.4 Grounding Considerations	09
5.5 Preparation	09
5.6 Installation Steps	10
<b>6. Monitoring system</b>	<b>12</b>
6.1 APP Installation Requirements	12
6.2 Add Equipment	13
6.3 APP Function	14
6.4 Status LED	15
6.5 Insulation Resistance Detection	15
6.6 On-site Inspection (Qualified Installers Only)	16
6.7 Routine Maintenance	16
6.8 Micro Inverter Replacement	17
6.9 Precautions	17
<b>7. Retired</b>	<b>18</b>
7.1 Retired	18
7.2 Storage And Transportation	18
7.3 Deal With	18
<b>Appendix 1:</b>	<b>19</b>
Instructions	19
<b>Appendix 2:</b>	<b>20</b>
Wiring Diagram - 230 VAC Single Phase:	20
Wiring Diagram - 230 VAC 3 Phase:	21
Wiring Diagram - 120 VAC / 240 VAC Split Phase:	22
Wiring Diagram - 120 VAC / 208 VAC 3 Phase:	23

# 1. Important Notes

## 1.1 Product Range

This manual mainly introduces the assembly, commissioning, maintenance and troubleshooting methods of "WVC-1200/WVC-1400/WVC-1600/WVC-2000/WVC-2400/WVC-2800" intelligent micro inverters. This product has passed the following certifications



- DIN VDE 0126-1-1 (VDE V 0126-1-1):2013-08 VFR 2019
- EN 55011:2016+A2:2021;BS EN 55011:2016+A2:2021
- EN IEC 61000-3-2:2019+A1:2021; EN IEC 62311:2020
- EN 301 489-1 V2.2.3 (2019-11);IEEE 1547A:2014
- ABNT NBR 16149:2013;ABNT NBR 16150:2013
- DIN VDE V 0126-1-1 (VDE V 0126-1-1):2013-08
- DIN VDE V 0124-100 (VDE V 0124-100):2012-07
- EN 300 328 V2.2.2 (2019-07)
- ANEXO III – parte 2, Portaria n,º 357, de 01 de agosto de 2014
- VDE-AR-N 4105 (VDE-AR-N 4105):2011-08
- BS EN IEC 61000-3-2:2019+A1:2021
- IEC 62109-1:2010; IEC 62109-2:2011
- CISPR 11:2015/AMD2:2019
- UL 1741:2010 Ed.2+R:16Sep2020
- CSA C22.2#107.1:2016 Ed.4
- ABNT NBR IEC 62116:2012
- EN 301 489-17 V3.2.4 (2020-09)

## 1.2 Target users

For safety reasons, technicians responsible for the installation, operation and maintenance of this micro inverter must have the corresponding qualifications, have received relevant training and master the relevant skills, and should strictly follow the instructions in this manual during installation, operation and maintenance.

## 1.3 symbols used

The safety symbols in this user manual are shown below.

legend	illustrate
	<p>Indicates a hazardous situation that could result in a hazard of fatal electric shock, other serious bodily injury, or a fire hazard.</p>
	<p>Hereby, Dongguan Kaideng Energy Technology Co., Ltd. declares that this product is in compliance with the essential requirements and other relevant provisions of Directive 2014/53/EU. You can find the Declaration of Conformity on <a href="http://www.kaidengdg.com">www.kaidengdg.com</a>.</p> <ul style="list-style-type: none"> <li>• Instructions are instructions that must be fully understood and followed to avoid potential safety hazards, including equipment damage or personal injury.</li> <li>• Please install the inverter under the solar panel during installation, and the DC cable from the solar panel to the inverter should not exceed 3m.</li> </ul> <p>This device complies with Part 15 of the FCC Rules. Operation is Subject to the following two conditions:</p> <ol style="list-style-type: none"> <li>1.This device may not cause harmful interference</li> <li>2.This device must accept any interference received.including interference that may cause undesired operation.</li> </ol>
	<ul style="list-style-type: none"> <li>• Indicates that the described action must not be performed. Thereader should stop, use it with caution, and fully understand theoperation described before proceeding.</li> <li>• Risk of etric shock Normally grounded condutors maybe ung rounded and energized when a grundnd-fault is indicated.</li> <li>• Do not remove cover mo user serviceable parts inside Refer servic ing to qualfed service personnel.</li> <li>• Both AC and DC voltage sources are trminated inside this equipment. Each circui must be individually disconnected befoue servicing.</li> <li>• When the photovoltaic aray is exposed to light. it spllies a DC voltage to this equipment.</li> <li>• To be connected only to a dicated banch circuit Maximumm branch circuit over current protection: 35A</li> </ul>









## 2. About safety

### 2.1 Important Safety Instructions

WVC-1200/1400/1600/2000/2400/2800 Micro inverters are designed and tested according to international safety requirements. But precautions must be taken when installing and operating this microinverter. The installer must read and follow all instructions, precautions and warnings in this installation manual.

<ul style="list-style-type: none"> <li>• All operations, including transport, installation, start-up and maintenance, must be carried out by qualified and trained personnel.</li> </ul>
<ul style="list-style-type: none"> <li>• Before installation, inspect the equipment to ensure there is no shipping or handling damage that could affect insulation integrity or safety clearances. Choose the installation location carefully and adhere to the specified cooling requirements. Unauthorized removal of necessary protective devices, improper use, and incorrect installation and operation can result in serious safety and electric shock hazards or equipment damage.</li> </ul>
<ul style="list-style-type: none"> <li>• Before connecting the microinverter to the distribution grid, please contact the local distribution grid company to obtain the appropriate approvals. This connection should only be made by a qualified technician. It is the installer's responsibility to provide an external disconnect switch and overcurrent protection device (OCPD).</li> </ul>
<ul style="list-style-type: none"> <li>• Only one PV module can be connected to one input of the micro-inverter. Do not connect batteries or other power sources. Microinverters should only be used after observing and applying all technical characteristics.</li> </ul>
<ul style="list-style-type: none"> <li>• Do not install the device in harsh environments such as flammable, explosive, corrosive, extremely hot or cold, and humid. Do not use the device when the safety device is not working or disabled.</li> </ul>
<ul style="list-style-type: none"> <li>• Always use personal protective equipment including gloves and goggles when installing.</li> </ul>
<ul style="list-style-type: none"> <li>• Notify the manufacturer of non-standard installation conditions.</li> </ul>
<ul style="list-style-type: none"> <li>• Do not use the device if any abnormality is observed during operation. Avoid temporary repairs.</li> </ul>
<ul style="list-style-type: none"> <li>• All repairs should be performed using only qualified spare parts, which must be installed in accordance with their intended use and by a licensed contractor or authorized service representative.</li> </ul>
<ul style="list-style-type: none"> <li>• Any liability arising from commercial components rests with their respective manufacturers.</li> </ul>
<ul style="list-style-type: none"> <li>• Exercise extreme caution whenever the microinverter is disconnected from the public network, as some components may retain enough charge to create an electric shock hazard. Before touching any part of the microinverter, ensure that surfaces and equipment are at a safe touch temperature and voltage potential before proceeding.</li> </ul>
<ul style="list-style-type: none"> <li>• We are not responsible for damages caused by errors or improper operation.</li> </ul>
<ul style="list-style-type: none"> <li>• Electrical installation and maintenance should be performed by a licensed electrician and should follow local wiring regulations.</li> </ul>

## 2.2 Symbol Description

Symbol	Usage
	<p><b>Recycle</b></p> <p>To comply with European Directive 2002/96/EC on Waste Electrical and Electronic Equipment and its implementation as national law, electrical equipment that has reached the end of its life must be separately collected and returned to an approved recycling facility. Any device no longer required must be returned to an authorized dealer or approved collection and recycling facility.</p>
	<p><b>Caution</b></p> <p>Do not come within 8 inches of the microinverter for any length of time while it is in operation.</p>
	<p><b>Danger of high voltages</b></p> <p>Danger to life due to high voltage in the microinverter.</p>
	<p><b>Beware of hot surface</b></p> <p>The microinverter can become hot while operating. Avoid contact with metal surfaces while operating.</p>
	<p><b>CE mark</b></p> <p>The microinverter complies with the requirements of the Low Voltage Directive for the European Union.</p>
	<p><b>Read manual first</b></p> <p>Please read the installation manual before installation, operation and maintenance.</p>

## 2.3 Radio Interference Statement

This microinverter has been tested and found to comply with the limits for CE EMC, which provides reasonable protection against harmful energy. However, if not installed according to the instructions, the microinverter may cause harmful interference to radio equipment. There is no guarantee that such interference will not occur during a particular installation.

To confirm that the radio or television reception is affected by interference from this equipment, turn the equipment off and on to test it. If this equipment causes harmful interference to the radio or television equipment, try to correct the interference through one or more of the following measures

- 1) Relocate the receiving antenna.
- 2) Increase the separation between the microinverter and the receiving antenna.
- 3) Place a shield between the microinverter and the receiving antenna.
- 4) Contact your dealer or an experienced radio/TV technician for help.

### 3. About Products

#### 3.1 About The 4-in-1 Unit

WVC-1200/1400/1600/2000/2400/2800 "4-in-1" Micro Inverter, DC operating voltage range should be greater than 22V and less than 60V. "4-in-1" series micro inverter WVC-1200/1400/1600/2000/2400/2800 is a reliable solution for even-panel photovoltaic systems and provides high CEC weighted efficiency. In 2015, it was 92.50% (peak efficiency 92.70%).

#### 3.2 Highlights

- The maximum output power can reach 1200W/1400W/1600W/2000W/2400W/2800W.
- Peak efficiency 92.70%. The CEC weighted efficiency is 92.50%.
- Static MPPT efficiency 99.80%. The efficiency of dynamic MPPT on cloudy days is 99.76%.
- Power Factor(Default/Adj) 0.99/0.95 Leading..0.95 Lagging.
- External antenna for stronger communication with WiFi sources.
- High reliability: NEMA 3R (IP67) enclosure. 2000 V surge protection.

#### 3.3 Terminals Introduction

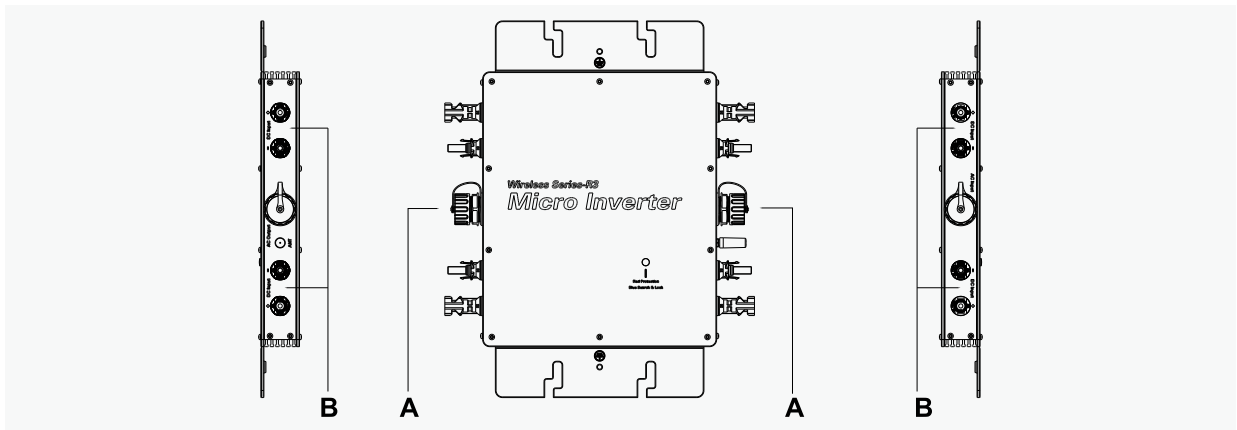

Object	Description
A	AC connector (female)
B	DC connection

#### 3.4 Dimension (mm)

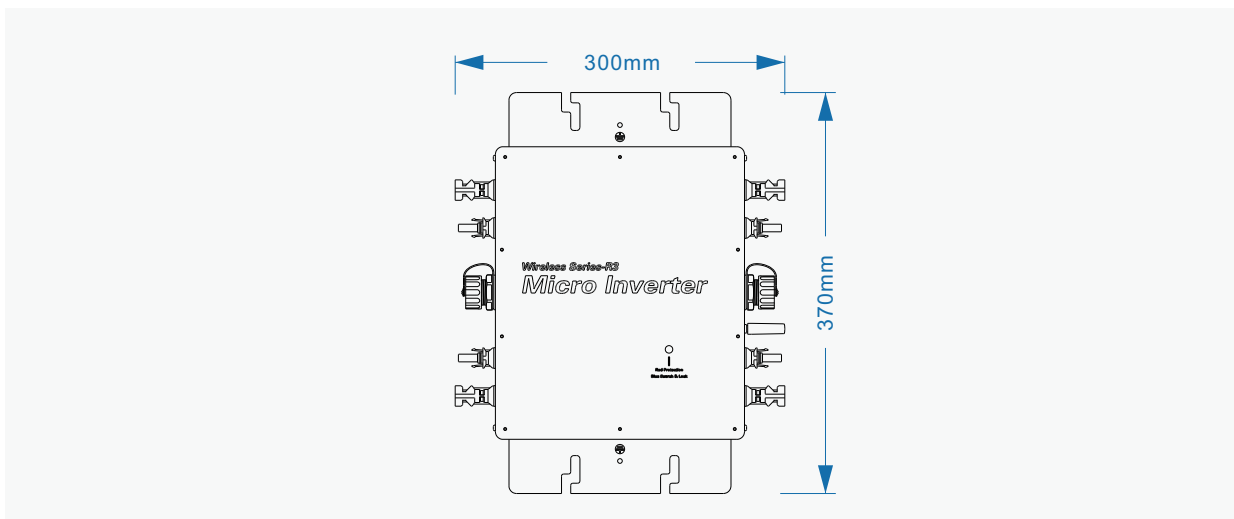

## 4. About Function

### 4.1 Work Mode

When the inverter is operating normally, the DC generated by the photovoltaic modules is converted into AC and supplied to household loads or fed into the public grid.

- When the inverter generates more power than the household load requires, the excess power will be fed into the grid.
- When the power generated by the inverter is less than required by the household load, it is supplemented by the grid.

## 5. About installation

### 5.1 Accessories

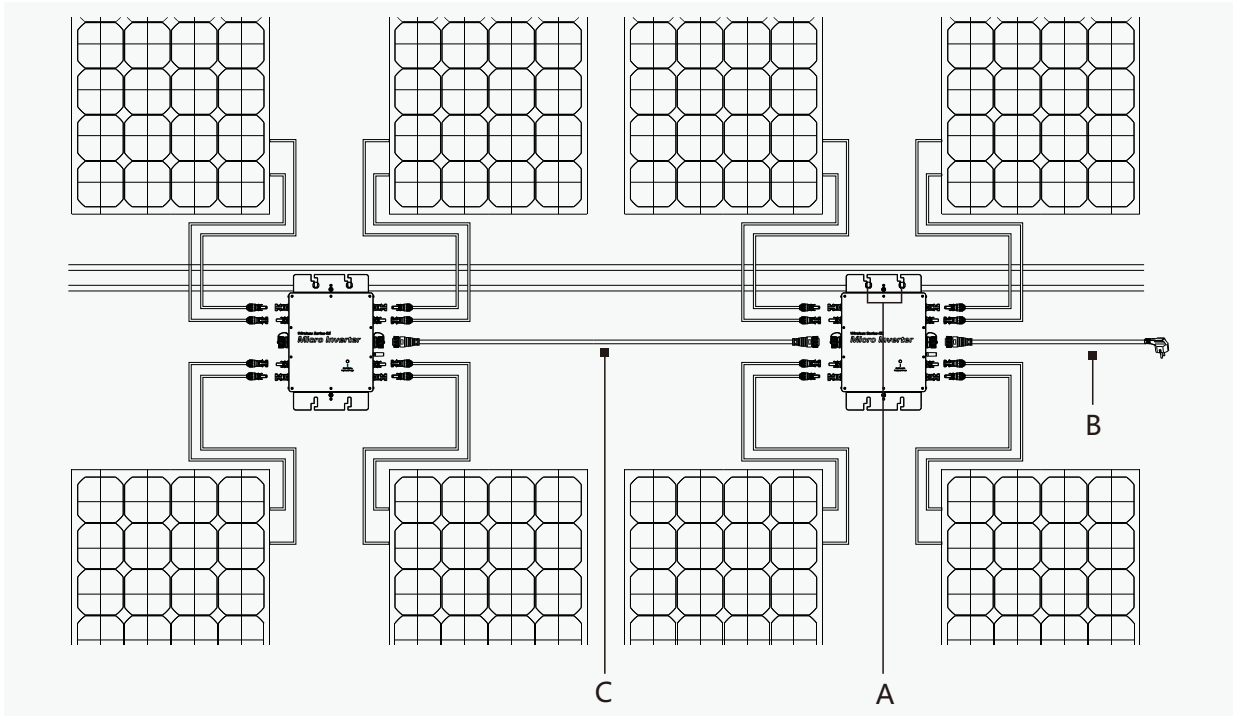

Object	Description
A	M8*20 screw set
B	AC Cable
*C	AC handshake line

\*Note: The AC handshake cable is used to connect two adjacent inverters. If you need to purchase, please contact the sales representative for price information and purchasing guidance.

### 5.2 Installation Precautions

Please install the inverter and all DC connectors under the PV modules to avoid rain, snow, UV rays and direct sunlight. Leave at least 5 cm of space around the microinverter housing to ensure ventilation and heat dissipation.\*Note: For some countries, local grid regulations (eg UKG98/99) are required.

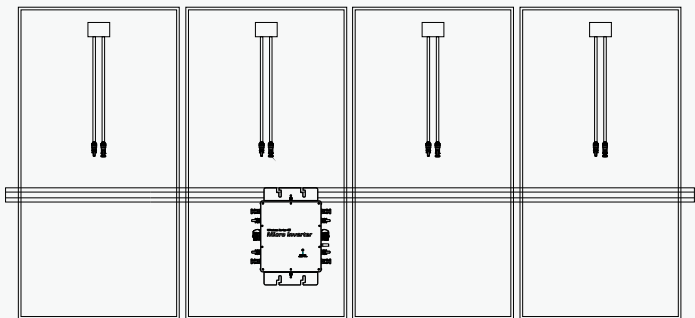

The back of the photovoltaic panel

### 5.3 Required Space Distance

If the micro-inverter is installed on a concrete roof or steel house, their communication with the WIFI router may be slightly affected. Under such installation conditions, the microinverter is best installed 50cm above the roof. Otherwise, it may be necessary to install a WIFI router nearby. The router ensures the quality of communication with the micro-inverter.

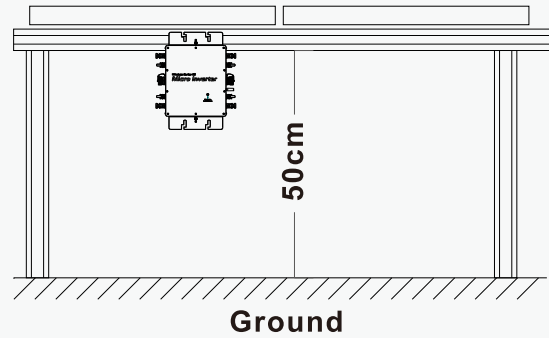

### 5.4 Grounding Considerations

This micro inverter is a Class I device with a basic isolation transformer and a ground wire inside the AC cable. This inverter must be grounded. When installing this inverter, the ground wire must be connected to the ground connection hole on the inverter casing.

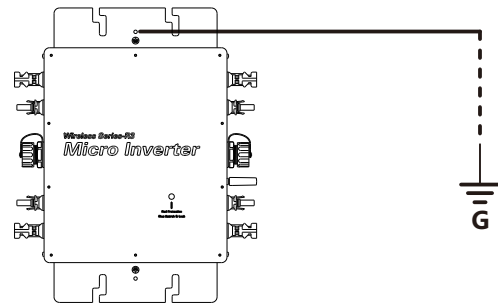

\*The inverter housing must be grounded

### 5.5 Preparation

Installation of this equipment is carried out based on the system design and the place in which the equipment is installed.

- Installation must be carried out with the equipment disconnected from the grid (power disconnect switch on) and with the PV modules shaded or isolated.
- Refer to the technical documentation to ensure that the environmental conditions meet the requirements of the micro-inverter (waterproof rating, temperature, etc.)
- To avoid power de-rating due to an increase in the internal temperature of the microinverter, do not expose it to direct sunlight.
- To avoid overheating, always ensure that the airflow around the microinverter is not obstructed.
- Do not install where gas or flammable substances may be present.
- Avoid electromagnetic interference that affects the normal operation of electronic equipment. When choosing an installation location, please observe the following conditions:

- Install only on structures specially designed for PV modules (provided by the installation technician)
- Install the inverter under the PV modules to ensure that it operates in a shaded or shaded environment. If this condition is not met, it may trigger the power drop of the inverter.

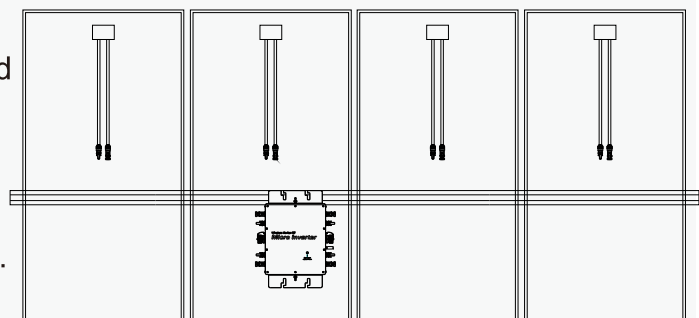

**Microinverter installation position**

## 5.6 Installation Steps

### Step 1. Mount The Micro Inverter On The Rail

- A) Mark the approximate center of each panel on the frame.
- B) Fasten the screws to the rail.
- C) Hang the micro-inverter on the screw (as shown on the rightshown) and tighten the screws. Silver cover for micro invertersShould face the panel.

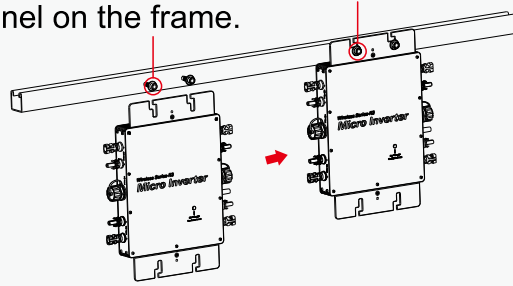

### Step 2. Install the cables

#### Mode 1) Connect only one device

Insert the AC grid connection cable terminal (male) into the inverter output terminal (female)

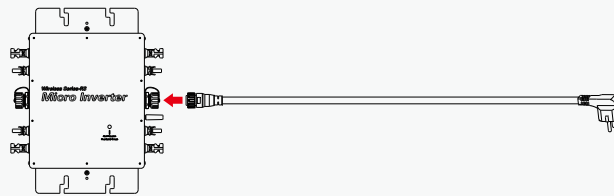

Inverter output terminal (female) internal cable wiring diagram

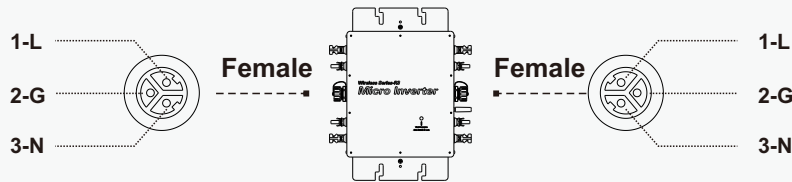

#### Mode 2) When connecting two or more devices

Use the handshake cable to connect adjacent inverters (a), connect the grid connection cable (a) to the first inverter, and tighten the waterproof cap of the inverter at the end (c) to form a complete circuit.

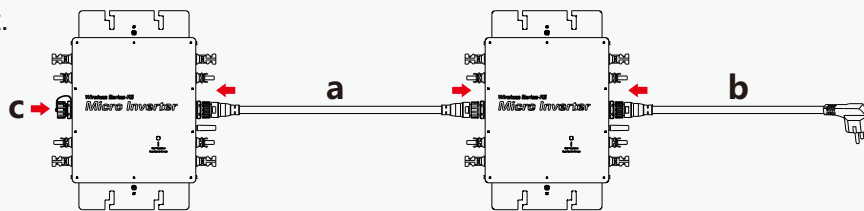

#### \*AC Cable diagram

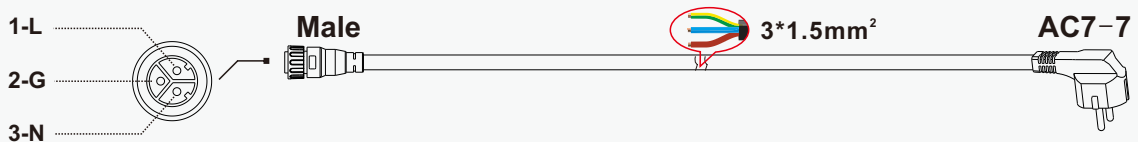

#### \*Handshake line diagram (additional purchase required)

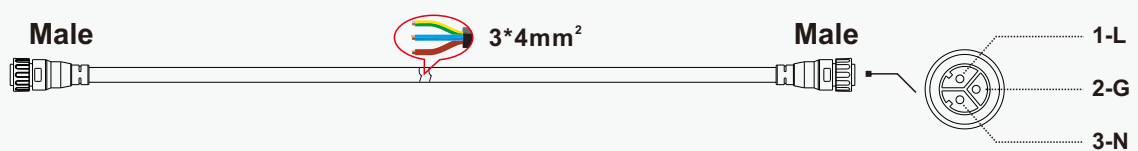

**Step 3. Connect to the grid**

Mode 1) Plug the included AC cable into the outlet



Method 2) Connect the end cable to the AC box (see Appendix 2)

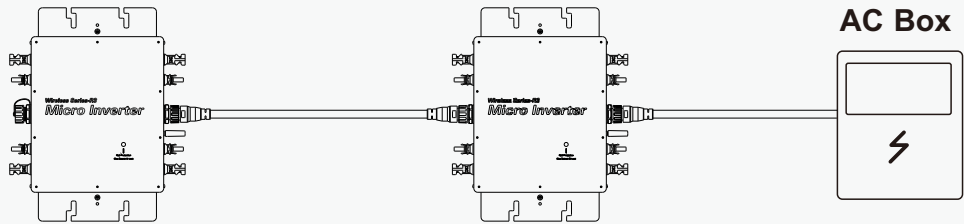

**Step 4. Create An Installation Diagram**

A) Tear off the QR code on the outer box of the micro inverter(The QR code label style is shown on the right).

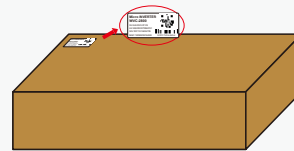

B) Paste the QR code label to the corresponding position on the installation drawing.

A table titled 'Micro inverter installation drawing'. It has columns for 'Inverter Type', 'Inverter Model', 'Inverter Location', and 'Inverter Capacity'. Below the header are several empty rows for data entry.

**Step 5. Connect The PV Modules**

A) Install the PV modules on the micro-inverter above.

B) Connect the DC cables of the PV modules to DC input side of the microinverter.

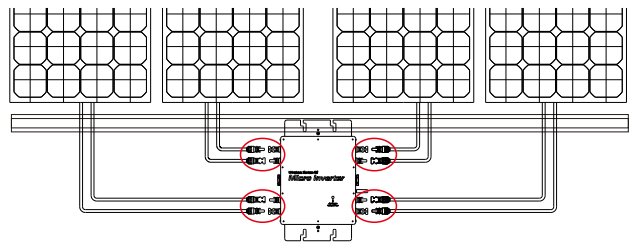

**Step 6. Power up the system**

- A) Open the AC circuit breaker for the branch circuit.
- B) Open the main AC circuit breaker of the house. Your system will start generating electricity after about a 30s wait time.

**Step 7. Set up the monitoring system**

Please refer to the "Smart Life" APP Monitoring Platform Quick Installation Guide to install and set up your monitoring system.



## 6. Monitoring System

### 6.1 APP Installation Requirements



You can search for "Smart Life" in Apple Store or Google StoreAPP or scan the QR code below to download and install the application.



China Ver



International Ver



Scan the QR code and select the country  
Download the "Smart Life" APP

### ! Mobile Phone Function Enabled

1. Please turn on the Bluetooth function. (Android system needs to turn on the positioning function);
2. Please use 2.4G Wi-Fi signal source;

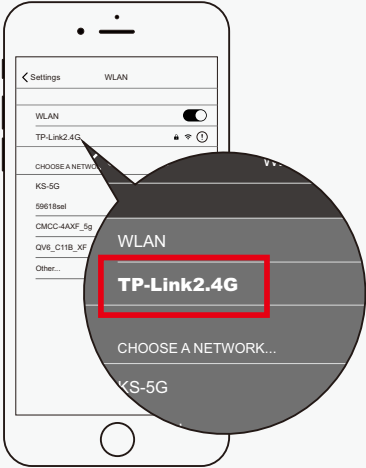
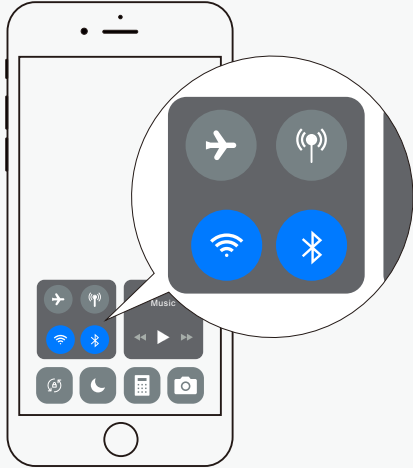

### ! Wireless Network Environment Requirements

Please use your mobile phone next to the inverter to check whether the 2.4G Wi-Fi signal source is good. If the Wi-Fi signal is poor, please adjust the location of the wireless router or add a WiFi signal booster to ensure that the inverter can operate in a good WiFi coverage environment.

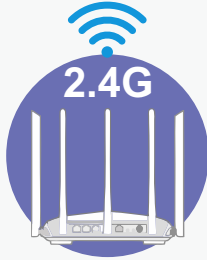
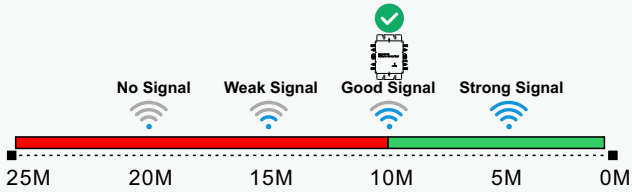
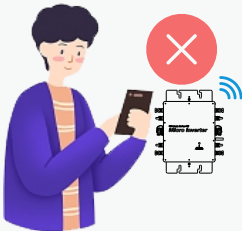

## 6.2 Add Equipment

### Bluetooth Mode

**Step 1.** Open the Smart Life, click "+" in the upper right corner and then click Add Device.

**Step 2.** When the device appears on the search page, click "Add", as shown in Figure 2

\*If the device cannot be searched, please check whether the inverter is too far away from the mobile phone,

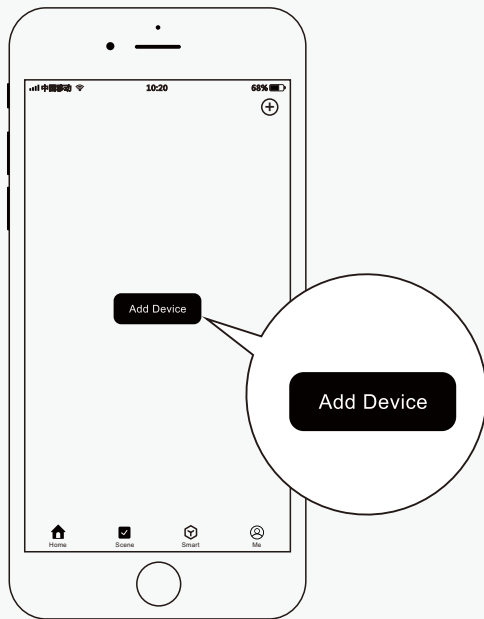

Figure 1

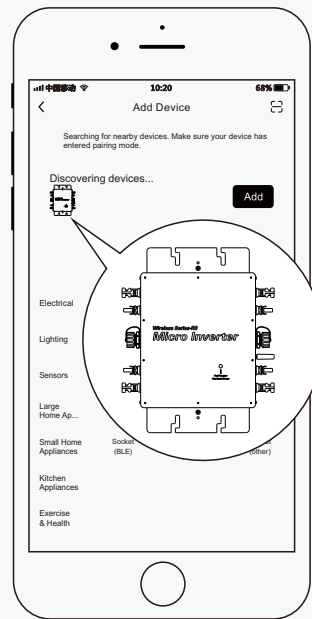

Figure 2

**Step 3.** When Figure 3 appears, please select the 2.4G wireless network and enter the correct password and click Next.

**Step 4.** When the inverter completes network distribution and displays the interface as shown in Figure 4, click "Done".

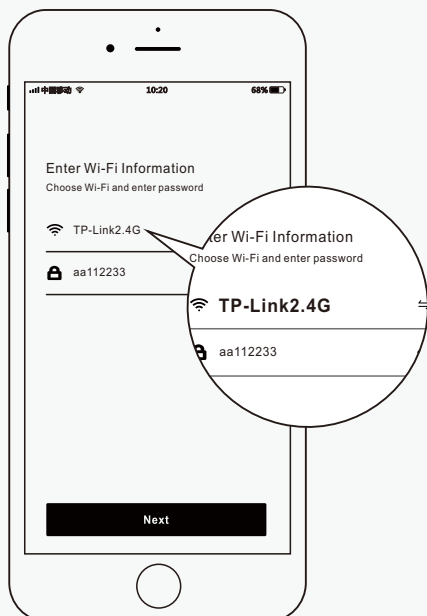

Figure 3

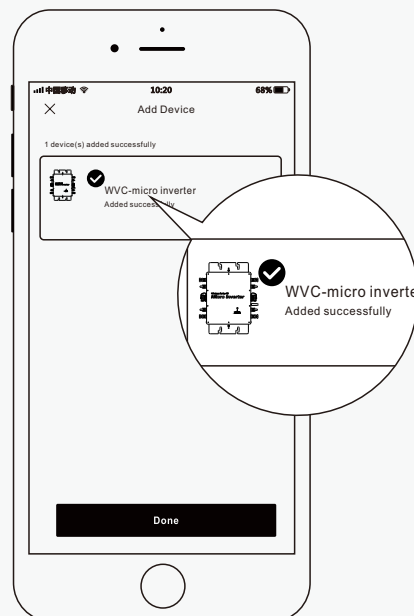
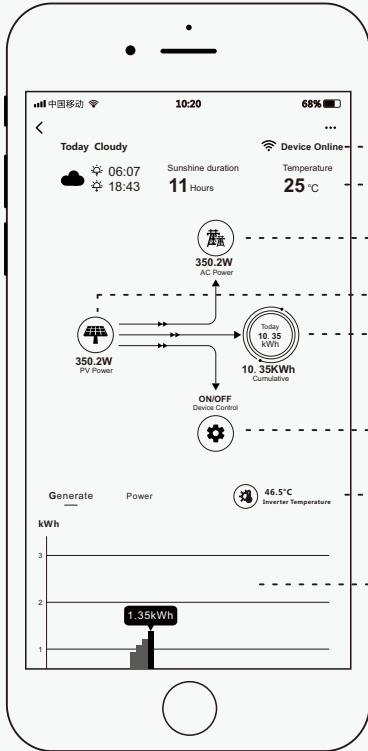

Figure 4

## 6.3 APP Function



### Main Interface



- Device Network Status
- Weather Conditions
- AC Power ( Click to View Detailed Function Display )
- PV Power ( Click to View Detailed Function Display )
- Today ( Click to View Detailed Function Display )
- Control ( Click to View Detailed Function Display )
- Inverter Temperature
- Power Generation/Power Display



### Interface and Function

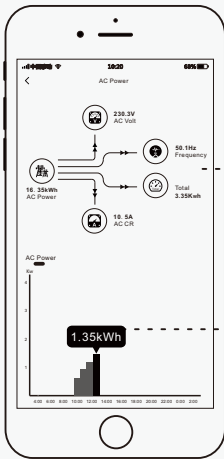

- AC Details
- AC Power

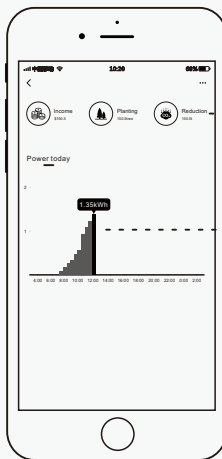

- Energy Saving Data Display
- Power Generation Today

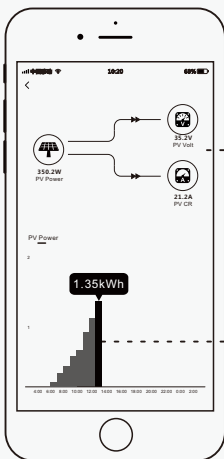

- PV Details
- PV Power

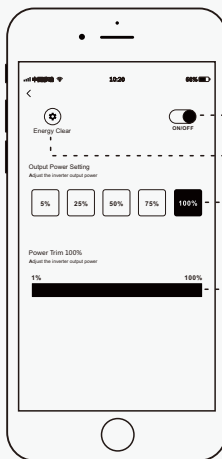







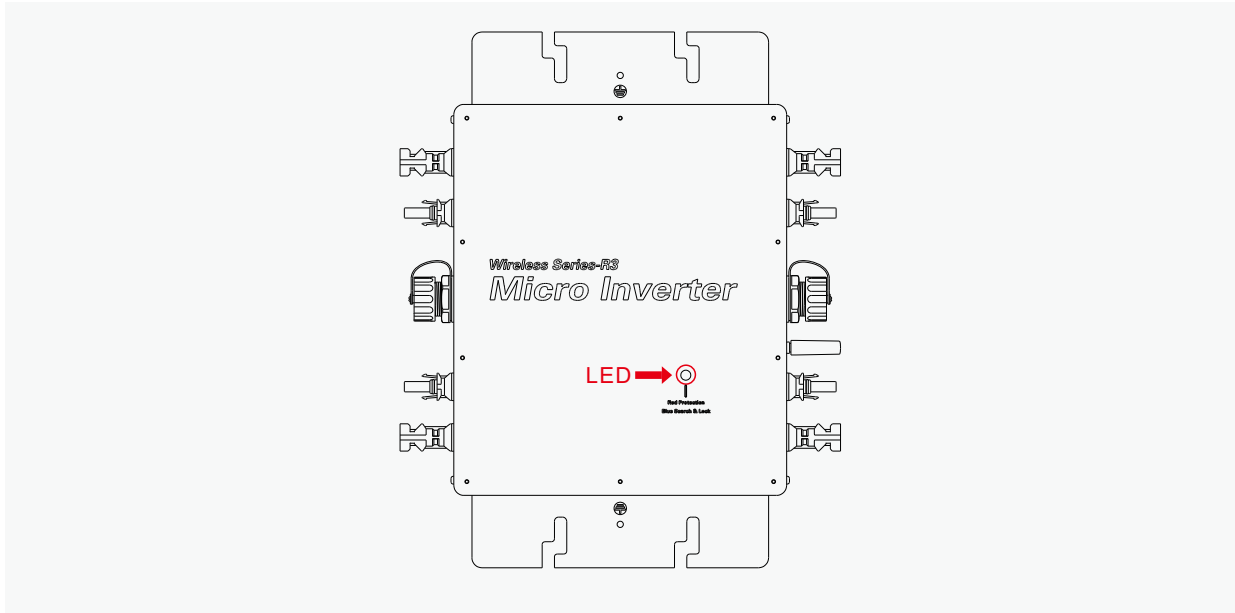

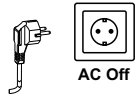

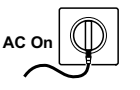
- Inverter On/Off
- Energy Clear
- Output Power Setting
- Power Trim

## 6.4 Status LED

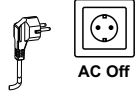
The red LED flashes (3s interval) when WiFi is not configured. When it is detected that the DC voltage and the AC voltage are normal, the startup state is entered.

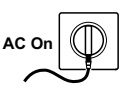

Power Outlet	Add to Smart life	LED Light Display	Description Explanation
 AC Off			Led Light Flashes Red
 AC On		  3s 1s	The LED light flashes blue/steady on, and the red LED light flashes once every 3s.
 AC Off			Red LED light always on
 AC On			Blue LED light is always on (MPPT lock)/blue LED light flashes (MPPT tracking)

## 6.5 Insulation Resistance Detection

There is a resistance sensor in the microinverter that measures the resistance between the output of the PV module and ground. If there is a problem with the insulation of the PV module, the DC wiring of the module or the connector, etc., it may cause the resistance between the module output and the ground to decrease.

If this resistance falls below a preset threshold, the microinverter will stop generating electricity and report this ground fault. This fault will continue until cleared on the cloud intelligent monitoring platform. The fault will continue until the micro-inverter restarts.

Note that this failure cannot be cleared if the cause of the failure still exists. If the fault persists, Please contact your salesperson for a solution.







**6.6 On-site Inspection (Qualified Installers Only)**

To troubleshoot an inoperable microinverter, follow the steps below.

1	Verify that the mains voltage and frequency are within the ranges shown in this microinverter technical data appendix.
2	Check the connection to the grid. Disconnect the AC and DC power supplies. Note! When the inverter is running, please disconnect the AC power first, cut off the inverter power, and then disconnect the DC power. Reconnect the PV panels and micro-inverter. After the connection is completed, the LED light will turn red, indicating that the DC side wiring is normal. Reconnect the AC power supply. The LED light will flash red quickly for 30 seconds and then enter the normal output state. Never disconnect the DC side connection of the micro-inverter while it is running.
3	Check the AC branch circuits between all inverters and that each inverter is powered by the utility grid, as in the previous step.
4	Make sure all AC circuit breakers are working and closed.
5	Check the DC connection between the microinverter and the PV modules.
6	Verify that the PV module DC voltage is within the allowable range shown in the technical data appendix of this manual.
7	If the problem persists, please call Customer Support.
	Don't try to repair the microinverter. If troubleshooting fails, return it to the factory for replacement.

**6.7 Routine Maintenance**

1. Only authorized personnel are allowed to perform maintenance operations, and authorized personnel are responsible for reporting any abnormal conditions.
2. When performing maintenance, always use the personal protective equipment provided by your employer.
3. During normal operation, check that the environmental and logistical conditions are correct. Make sure that these conditions have not changed over time and that the equipment has not been exposed to severe weather conditions and not covered by foreign objects.
4. Do not use it if you find a problem, and restore it to the original state after the problem is solved.
5. Carry out annual inspection of each component, and use a vacuum cleaner or special brush to clean the equipment.

	Do not attempt to disassemble the inverter or perform any internal repairs! Unauthorized private repairs will void your warranty.
	The AC output harness (AC breakout cable on the microinverter) cannot be replaced. If the power cord is damaged, the device should be scrapped.
	Unless otherwise specified, maintenance operations must be performed with all connections to the AC side and DC side of the inverter disconnected.
	When cleaning, do not use wipes made of filamentous materials or corrosive products that may corrode equipment parts or generate static charges.
	Avoid temporary repairs. All repairs should be carried out using only original spare parts.
	A 40 A circuit breaker should be provided for each branch circuit, but no central protection unit is required.

## 6.8 Micro Inverter Replacement

<b>a. How to disassemble the microinverter:</b>
<ul style="list-style-type: none"> <li>• Disconnect power from the AC branch circuit breaker.</li> </ul>
<ul style="list-style-type: none"> <li>• Remove the PV panel from the bracket and cover the panel.</li> </ul>
<ul style="list-style-type: none"> <li>• Use a meter to measure and make sure there is no current flowing in the DC wires between the panel and the microinverter.</li> </ul>
<ul style="list-style-type: none"> <li>• Use the DC disconnect tool to remove the DC connector.</li> </ul>
<ul style="list-style-type: none"> <li>• Use the AC disconnect tool to remove the AC connector.</li> </ul>
<ul style="list-style-type: none"> <li>• Unscrew the fixing screws on the top of the micro-inverter and remove the micro-inverter from the PV support.</li> </ul>
<b>b. How to replace the microinverter:</b>
<ul style="list-style-type: none"> <li>• Please note the SN of the new microinverter.</li> </ul>
<ul style="list-style-type: none"> <li>• Make sure the AC branch circuit breaker is turned off, then follow the microinverter installation steps to install the replacement unit.</li> </ul>
<ul style="list-style-type: none"> <li>• Enter the monitoring platform (if the customer has already registered the site online), enter the "Device" page, and re-add a new device according to the conventional method of adding an inverter to complete the replacement.</li> </ul>

## 6.9 Precautions

	Warning: Be sure to verify the following before installing a Microinverter system.
	Verify that the voltage and current specifications of the PV modules match those of the microinverter.
	The maximum open circuit voltage rating of the PV modules must be within the operating voltage range of the microinverter.
	It is recommended that the maximum rated current of the MPPT $\leq$ the maximum input DC current. But the maximum short-circuit current must be less than or equal to the maximum input DC short-circuit current.
	The output DC power of photovoltaic modules is not recommended to exceed 1.35 times the output AC power of the micro-inverter.
	Warning: additional protective earthing wire with minimum cross-section 6mm <sup>2</sup>

## 7. Retired

### 7.1 Retired

Disconnect the microinverter from the DC input and AC output. Remove all connecting cables from the micro inverter. Remove the microinverter from the frame.

Pack the micro-inverter in its original packaging, or use a 5kg carton that can be completely closed if the original packaging is no longer available.

### 7.2 Storage And Transportation

Uses suitable means to package and protect individual components for easy shipping and subsequent handling. Transportation of equipment, especially by road, must be carried out in a manner suitable for protecting components, especially electronic components, from violence, shock, moisture, vibration, etc. Properly dispose of packaged components to avoid accidental injury.

It is the customer's responsibility to check the condition of the shipping parts. After receiving the micro inverter, it is necessary to inspect the container for any external damage and confirm receipt of all items. If damage or missing components are detected, please call the delivery carrier immediately. If inspection reveals damage to the micro inverter, please contact the supplier or authorized distributor for a repair/return decision and instructions on the process.

Micro inverter storage temperature from -20°C to 50°C

### 7.3 Deal With

- If the device is not for immediate use or long-term storage, make sure it is properly packaged. Equipment must be stored in a well-ventilated inner area that does not have characteristics that could damage equipment components.
- A full inspection should be carried out when restarting after a prolonged or prolonged cessation of use.
- For end-of-life equipment that may be hazardous to the environment, properly dispose of the equipment in accordance with the regulations in force in the country where it is installed.

# Appendix 1: Instructions

<b>Micro Inverter Installation Drawing</b>										
North 	Panel Type: Azimuth: Tilt: Sheet _____				Customer Information:			Serial Number:		
Array	1	2	3	4	5	6	7	8	9	10
A										
B										
C										
D										
E										



# Appendix 2: Wiring Diagram @230 VAC Single Phase:

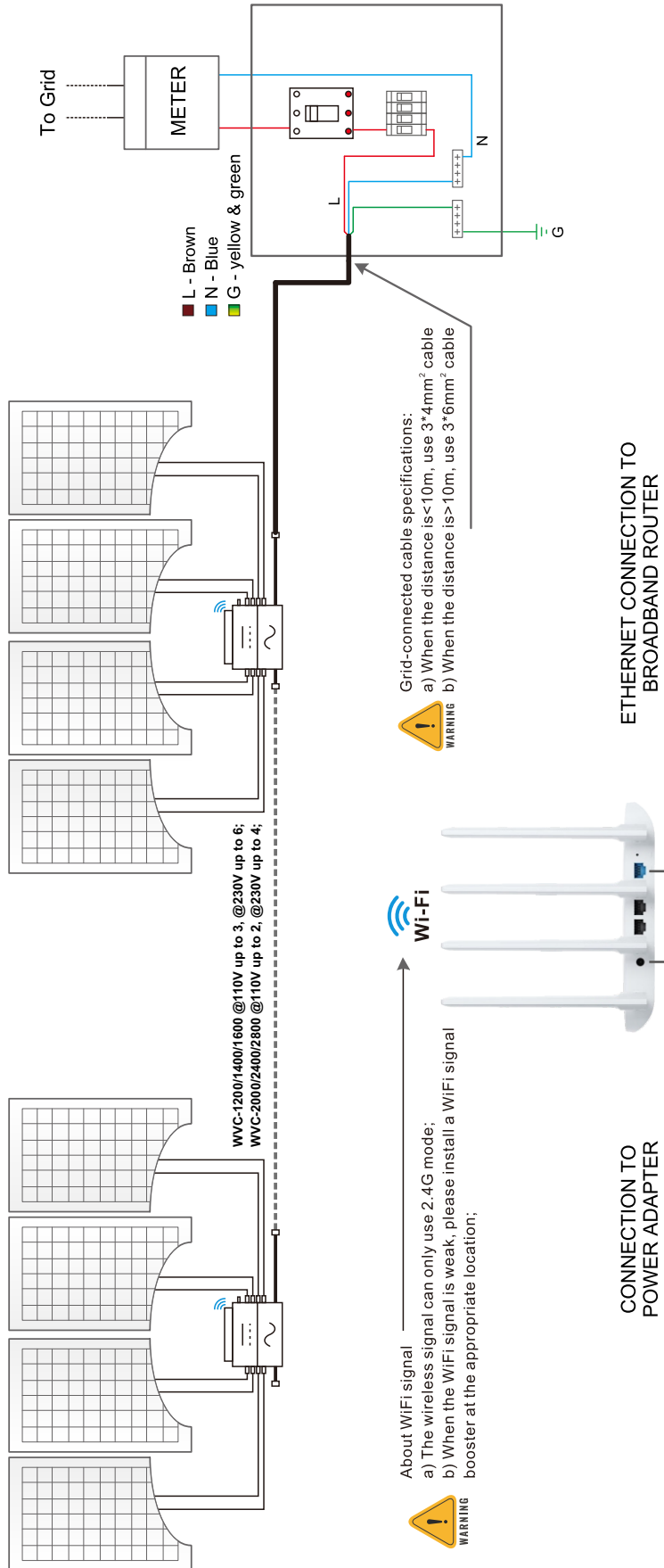

# Wiring Diagram @230 VAC 3 Phase:

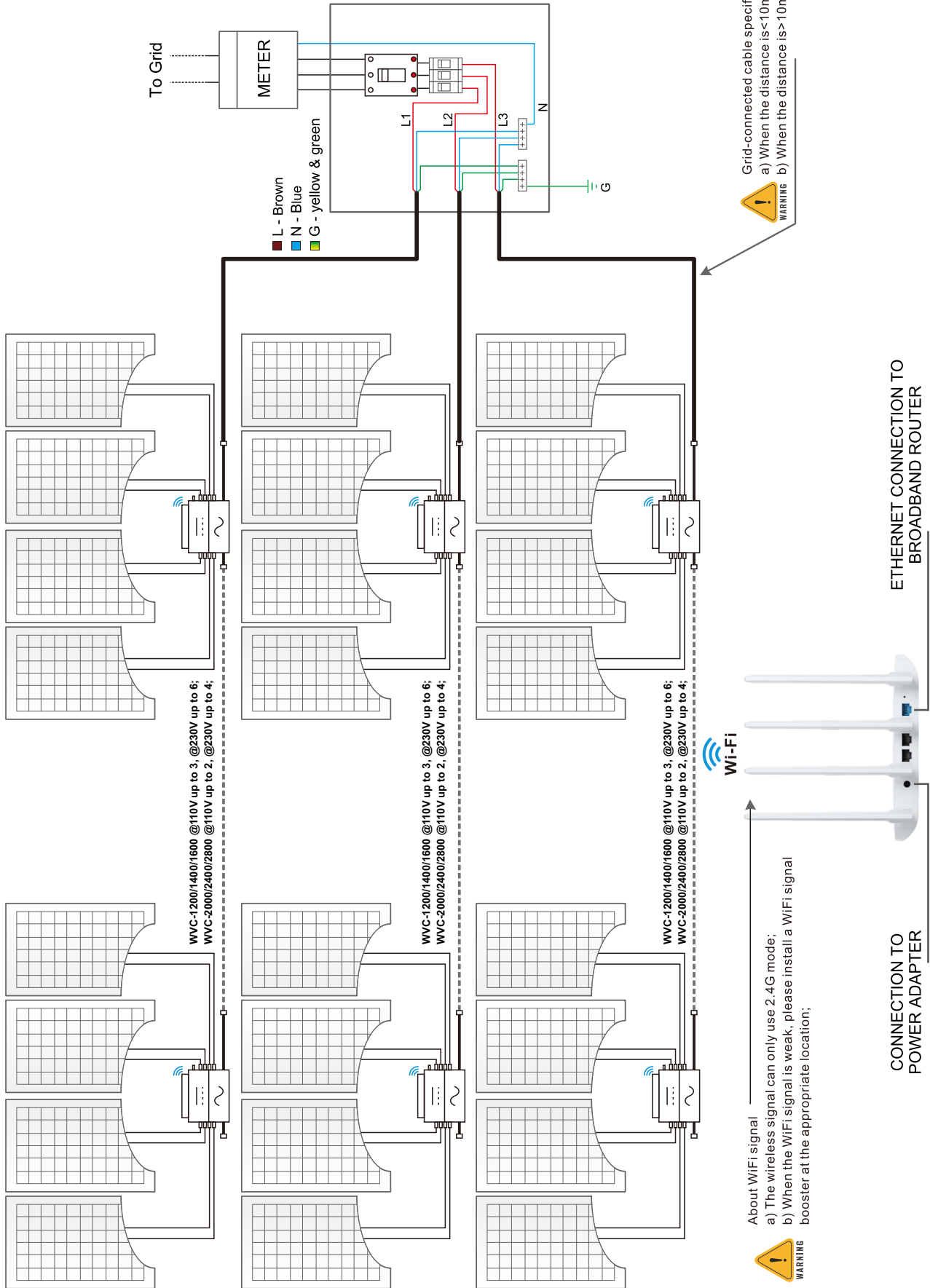

# Wiring Diagram @120 VAC / 240 VAC Split Phase:

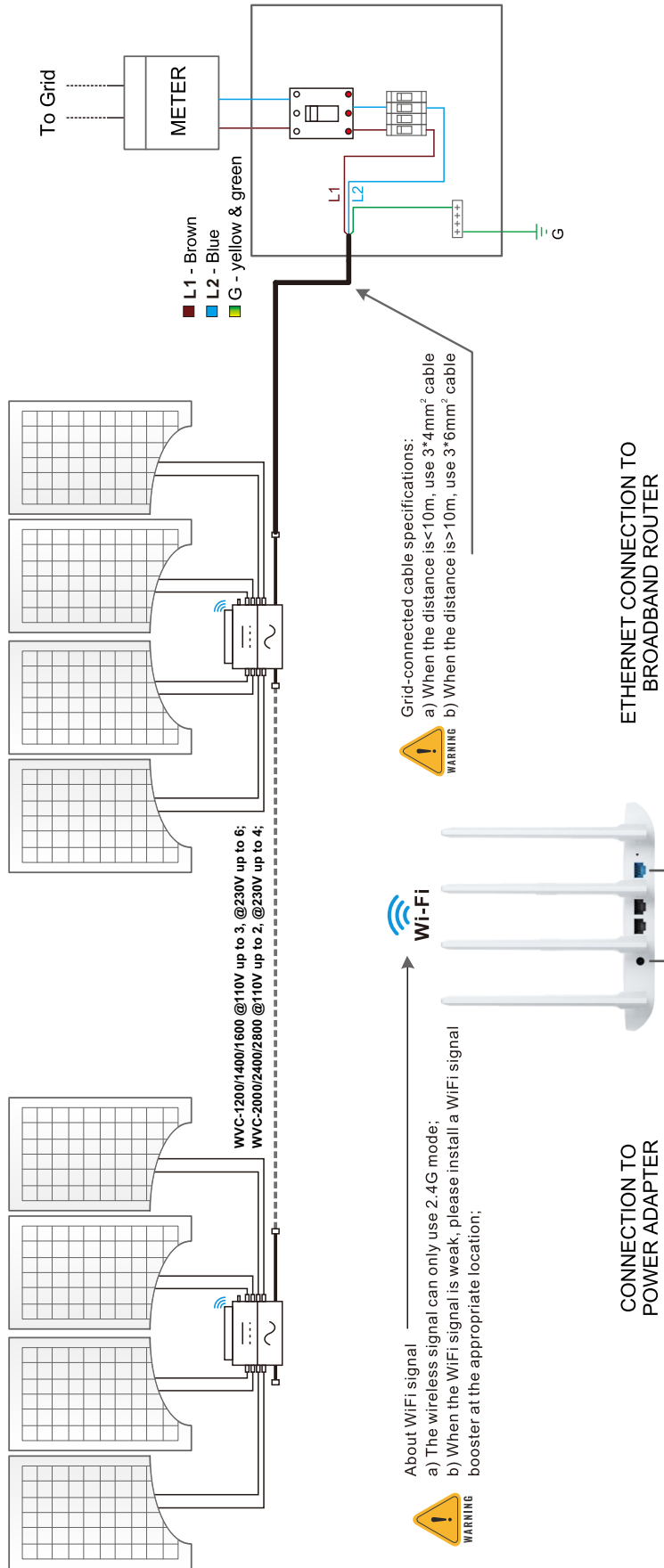

# Wiring Diagram @120 VAC / 208 VAC 3 Phase:

